

A Demonstration of Seamless Inter-Technology Mobility in Heterogeneous Networks

Patrick Bosch*, Tom De Schepper*, Ensar Zeljković*, Farouk Mahfoudhi*,
Yorick De Bock*, Jeroen Famaey*, and Steven Latré*

*University of Antwerp - imec, IDLab, Department of Mathematics and Computer Science, Belgium
firstname.lastname@uantwerpen.be

Abstract—Today’s electronic devices have multiple communication technologies available at any time. Currently, the application layer or the user needs to manually switch between them, depending on the networks in range. No holistic and adaptive approach exists that can manage all technologies and devices at once. To this extent, we previously proposed the inter-technology management framework ORCHESTRA. The framework is the first of its kind in providing fine-grained packet-level control across different network technologies in a network-wide manner. In this paper, we present a real-life implementation of this framework and show that it can cope well with mobility requirements of users by offering seamless inter-technology handovers.

I. INTRODUCTION

Wireless networks have become indispensable and are widespread in today’s world. Most people want to remain connected to the Internet at all times and places by, for instance, using smartphones that are equipped with, amongst others, wireless technologies like Long-Term Evolution (LTE), IEEE 802.11 (Wi-Fi), and Bluetooth. Similarly, we are currently experiencing the rise of the Internet of Things (IoT) that introduces billions of connected devices, all equipped with different wireless technologies (e.g., LoRa or IEEE 802.11ah). In the future, this growth and diversity among technologies and connected devices will further increase with technological advancements and new technologies being standardized (e.g., IEEE 802.11ay and IEEE 802.11ax) [1, 2]. Furthermore, the current applications have stringent and diverse quality requirements (e.g., high throughput for multi-media applications) and are very sensitive to network disruptions and degradations (e.g., high latency, congestion, or link failures).

Current network management solutions are not able to cope with and fully exploit the heterogeneity among communication technologies. This despite the aid that could be provided to meet the ever-growing traffic and quality demands. The main problem lays in the independent operations of each of these technologies, isolated from each other. Cooperation between them is infeasible due to the current design of the lower layers of the Open Systems Interconnection (OSI) stack [3]. Switching between technologies or load balancing is delegated to the application layer, or even worse, to the user. This very static management of these heterogeneous wireless networks makes it impossible to automatically react in a timely fashion to dynamic network changes (e.g., disruption or varying traffic demands), while a more efficient use and

management of wireless resources would allow devices to fully exploit the diversity of wireless access technologies. Furthermore, existing inter-technology solutions like Multipath Transmission Control Protocol (MPTCP) and LTE-Wireless Local Area Network (WLAN) Aggregation (LWA), fail to provide a fine-grained, coordinated, and transparent answer to this heterogeneity [4, 5].

To cope with the above mentioned heterogeneity in wireless networks we previously proposed the ORCHESTRA framework [6]. This framework offers inter-technology management and consists of two major parts: the virtual MAC layer (VMAC) and the ORCHESTRA controller. The VMAC unifies the Medium Access Control (MAC) of the different supported technologies on a single device, providing a single point for connectivity to both the application layers and the ORCHESTRA controller. A Software-Defined Networking (SDN) based approach is used where a set of policies can be defined to control the VMAC behavior on a packet level. The controller has a global view over the network and is capable of managing both VMAC-enabled and legacy devices across the entire network, thereby enabling holistic centralized management. The main functionalities offered by ORCHESTRA are intra- and inter-technology seamless handovers, packet-based load balancing, and duplication of critical data.

In this paper, we present a real-life prototype implementation of the proposed framework. The functionality of the framework is demonstrated by means of a remote-controlled moving vehicle that is crossing different Wi-Fi and LTE coverage zones. When crossing different zones, a seamless handover of the traffic to and from the device is performed.

II. ORCHESTRA FRAMEWORK DESCRIPTION

The ORCHESTRA framework, combining the VMAC and the ORCHESTRA controller, was developed to offer a holistic management solution for heterogeneous networks, in particular wireless ones. It has two modes of operation, corresponding to the type of devices that are present in the network. The first mode corresponds to ORCHESTRA-enabled devices, in other words devices that are equipped with the VMAC. This allows for all the available flexibility, control, Quality of Service (QoS), and functionalities. In contrast, the second mode corresponds to devices that, compared to our solution, offer legacy functionality. For such devices, only the handover functionality remains through band-steering (intra-technology) and access

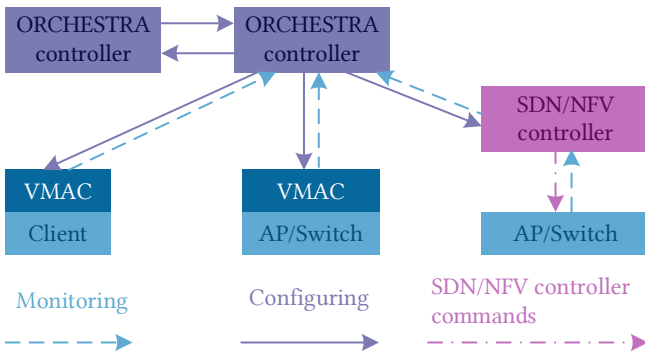

Fig. 1. Overview of the ORCHESTRA network management framework.

point (AP) roaming (inter-technology). The performance is highly depending on the client and needs to be supported by the infrastructure. An overview of the ORCHESTRA framework and the modes of operation is depicted in Figure 1.

A. ORCHESTRA virtual MAC layer (VMAC)

The VMAC is introduced to avoid connection loss when changing different interfaces (i.e., technologies) as it abstracts connectivity from the user and applications. It is located above the existing data link layers and below the network layer in the OSI model. Existing layers are thus not modified. At the sender side, the VMAC acts mainly as a switching panel for the different available network interfaces. When a packet is received from the network layer, it is matched with the rules that are currently in place, and then forwarded to the right interface. The packet forwarding rules can, for instance, be based on source and destination IP addresses, port, transport protocol type, sequence number and more. If demanded, load balancing and duplication occurs before pushing the packet out to the lower layer. In case of load balancing, packets of a specific traffic flow are divided across different interfaces based on weights. Similarly, packets can be duplicated and sent across multiple interfaces to increase the chance of arrival. At the receiver side, packets are received from the underlying data link layers and pushed to the network layer. In case of load balancing, reordering is necessary to limit the impact on transport protocols, in particular Transmission Control Protocol (TCP). This reordering is done based on sequence numbers. Similarly, for duplication, it is necessary to remove duplicated packets before pushing them upwards.

B. ORCHESTRA controller

While the VMAC allows for fine-grained MAC control inside a single node, the ORCHESTRA controller enables management and orchestration of the entire network. The controller combines all network logic and offers centralized decision making, including assignment of devices to end points or the routes assigned to packets. Monitoring information is received from VMAC enabled devices and possibly also from other networks devices (e.g., through communication with SDN-controllers). This offers a real-time state model of the entire network. The controller can contact an individual

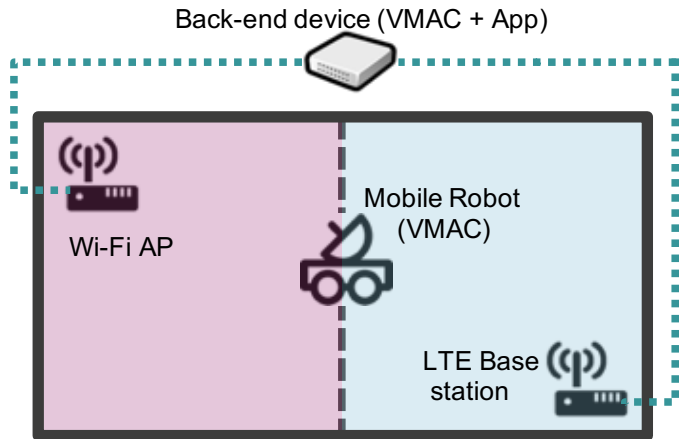

Fig. 2. Architecture of the demo setup

VMAC through a management protocol running over User Datagram Protocol (UDP). These packets are then intercepted by the virtual layer. This way, new configurations (e.g., new rules or the enabling of load balancing and duplication) can be installed. These communication patterns are depicted in Figure 1. Advanced algorithms can be run on top of the controller, making use of the real-time network overview and its configuration capabilities. It is, among others, possible to optimize the traffic routes through the network by balancing the traffic load across technologies and devices across AP. This leads to a significant increase in the network-wide throughput [6, 7, 8].

III. DEMO SETUP

The goal of the demo is to demonstrate the seamless mobility offered by the ORCHESTRA framework. We make use of our prototype ORCHESTRA implementation and our experience gained with a previous demo setup [6, 9]. Instead of using a static setup, we use a mobile robot in a restricted area that can be remotely controlled.

Figure 2 shows the different components of the demo setup. The network connectivity is provided by two wireless end points, placed in the opposite corners of the setup. One end point is a Wi-Fi AP, while the other is an LTE base station. The demo area is visually split in two zones that represent the coverage area of both wireless end points. The mobile robot, depicted in the middle of the figure, is allowed to freely drive around the constrained demo area (indicated by the black box around the setup). It can be controlled wireless by a remote control. The robot is equipped with two interfaces, one for Wi-Fi and LTE respectively, thereby making it possible to perform handovers between the two technologies. Furthermore, the robot is also equipped with the ORCHESTRA VMAC. As the control of the robot happens in real-time, this demo setup allows for the demonstration of the inter-technology seamless mobility introduced by the ORCHESTRA framework. We now discuss the scenario and setup of the demo in more detail.

A. Scenario and robot description

First of all, there is the mobile robot itself. The robot consists of a Raspberry Pi 3 with a wheel kit and camera. The camera is used to stream video to the remote control application. Moreover, for visual attractiveness of the demo booth, we show this captured video stream also on a large monitor. Visitors of the demo are able to steer the robot themselves. While driving around the robot can cross the two different colored zones, as depicted in Figure 2. When being in a certain zone the robot uses the corresponding wireless technology to receive its controls and transmit the captured video stream. For instance, when the robot would be at the right side of the demo area (indicated in blue), the LTE network will be used.

To initiate the handovers between the two technologies we implemented a simple object recognition application that can detect the color of the area. For this we made use of the OpenCV library. This application detects a transition between zones and will consequently initiate a handover from one technology to another. This application is running on an Intel Nuc that is connected by wire with both the Wi-Fi AP and the LTE base station. Similar to the mobile robot, it also has the VMAC implemented and acts as a back-end device. A second screen is used to show monitoring information from this VMAC to clearly illustrate to the visitor of the demo which technology is currently used and what the performance is. In terms of performance, we show, amongst others, throughput and packet loss.

B. VMAC implementation

The VMAC on both the robot and the back-end device is implemented using the Click Modular Router [10]. We opted for Click as it allows for fast and high-level prototyping, which is handy for ongoing research. We make use of existing Click elements for basic packet handling and communication with the different interfaces and layers. The VMAC logic for handling rule matching, reordering, and (de)duplication is implemented in new Click elements. As the VMAC exposes only a single interface to the upper layers, only a single IP address is used. Therefore, the VMAC implementation takes care of Dynamic Host Configuration Protocol (DHCP) and Address Resolution Protocol (ARP). As described previously, the packet flow is the following: for outgoing traffic, the single interface receives all traffic and applies functionality before forwarding packets to underlying interfaces. For incoming traffic, packets are forwarded from one of the interfaces and are reordered or de-duplicated in the case of load-balancing or duplication, before being pushed upwards. To support a seamless handover a buffer is implemented to buffer packets while setting up the new connection and tearing down the old one.

IV. SUMMARY

In this paper, we presented a demo setup for seamless mobility across different network technologies. In particular, we show how the ORCHESTRA framework allows for transparent and seamless handovers between, in this case, LTE and Wi-Fi.

The demo consists of a mobile robot, controlled by the visitor, that is connected to either one of the present technologies, depending on its location. When crossing to another coverage area, a inter-technology handover is performed without affecting real-time control and video traffic.

ACKNOWLEDGMENT

Patrick Bosch is funded by FWO, a fund for fundamental scientific research, and the Flemish Government under grant 1S56616N.

REFERENCES

- [1] Cisco, “Cisco Visual Networking Index: Global Mobile Data Traffic Forecast Update, 2016-2021,” *Cisco*, pp. 2016–2021, 2016.
- [2] M. S. Afaqui, E. Garcia-Villegas, and E. Lopez-Aguilera, “IEEE 802.11ax: Challenges and Requirements for Future High Efficiency WiFi,” *IEEE Wireless Communications*, vol. 24, no. 3, pp. 130–137, 2016.
- [3] R. Wang, H. Hu, and X. Yang, “Potentials and challenges of C-RAN supporting multi-RATs toward 5G mobile networks,” *IEEE Access*, vol. 2, pp. 1200–1208, 2014.
- [4] A. Ford, C. Raiciu, M. Handley, and O. Bonaventure, “TCP Extensions for Multipath Operation with Multiple Addresses,” *Tech. Rep.*, 2013. [Online]. Available: <https://www.rfc-editor.org/info/rfc6824>
- [5] C. Hoymann, D. Astely, M. Stattin, G. Wikström, J. F. T. Cheng, A. Höglund, M. Frenne, R. Blasco, J. Huschke, and F. Gunnarsson, “LTE release 14 outlook,” *IEEE Communications Magazine*, vol. 54, no. 6, pp. 44–49, 2016.
- [6] E. Zeljkovi, T. De Schepper, P. Bosch, I. Vermeulen, J. Haxhibeqiri, J. Hoebeke, J. Famaey, and S. Latre, “ORCHESTRA : Virtualized and Programmable Orchestration of Heterogeneous WLANs,” in *2017 13th International Conference on Network and Service Management (CNSM)*, 2017, pp. 1–9.
- [7] T. De Schepper, S. Latre, and J. Famaey, “Flow Management and Load Balancing in Dynamic Heterogeneous LANs,” *IEEE Transactions on Network and Service Management*, In Press.
- [8] —, “A transparent load balancing algorithm for heterogeneous Local Area Networks,” in *2017 IFIP/IEEE Symposium on Integrated Network and Service Management (IM)*, 2017, pp. 160–168.
- [9] T. De Schepper, P. Bosch, E. Zeljkovic, K. De Schepper, C. Hawinkel, S. Latré, and J. Famaey, “SDN-based transparent flow scheduling for heterogeneous wireless LANs,” in *Proceedings of the IM 2017 - 2017 IFIP/IEEE International Symposium on Integrated Network and Service Management*, 2017, pp. 901–902.
- [10] E. Kohler, R. Morris, B. Chen, J. Jannotti, and M. F. Kaashoek, “The click modular router,” *ACM Transactions on Computer Systems*, vol. 18, no. 3, pp. 263–297, 2000.